

BMW Welt in Munich

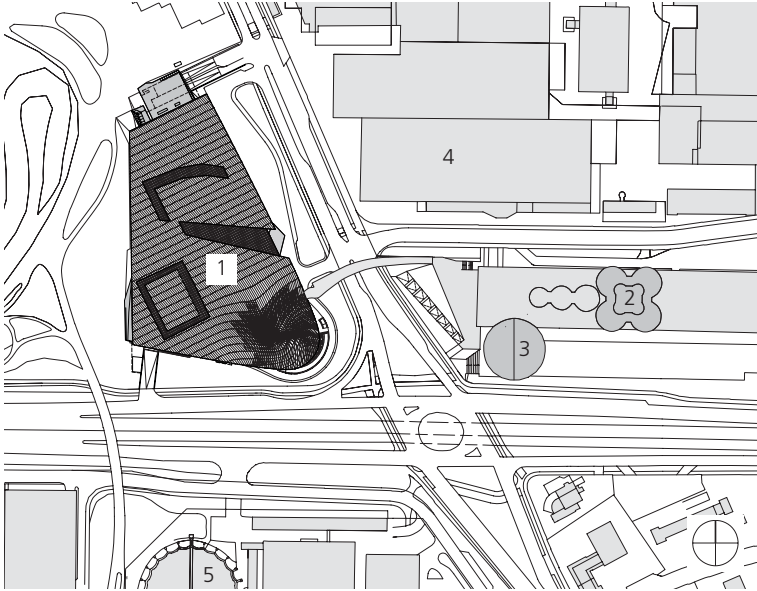

BMW WELT IN MUNICH



Site plan, scale 1:5000

- 1 BMW Welt
- 2 BMW Group headquarters
- 3 BMW Museum
- 4 BMW plant, Munich
- 5 Olympic ice rink

BMW's new brand-experience and delivery centre, BMW Welt, was opened in October 2007 on a site in Munich, in the district of Milbertshofen, where the motor manufacturer erected its first factory buildings in 1917. Standing opposite the famous 'Four Cylinder' tower (housing BMW's headquarters) and the BMW Museum, both designed by Karl Schwanzer, and the company's main car plant, it is an important new component in the public profile of the company and the brand. Located at a busy junction on a city ring road, with excellent links to the public transport system, BMW Welt is a prominent urban landmark. Its elegant design, by Viennese architects COOP HIMMELB(L)AU, represents a further architectural highlight in the north of the city, in line of sight of the world-famous Olympics complex with its iconic tented roof.



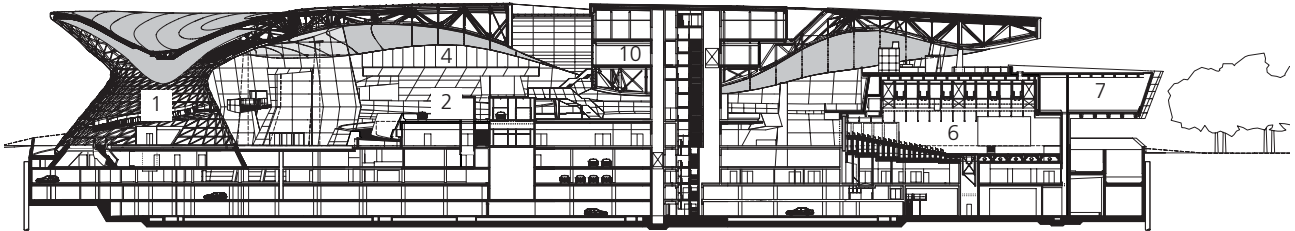

The various areas within BMW Welt are accommodated under a 'cloud-like' roof emerging from a double cone. This roof, 16,000 m² in area, up to 15 m high and clad entirely in stainless steel panels, rests on only a few columns and support points. As well as its protective function, the roof also both defines and encloses space. Its rising and falling underside articulates the hall below, marking out the different functional zones and giving the building its innovative and dynamic character.

Longitudinal section · Plan of Level 2
scale 1:1500

- 1 Double cone
- 2 'Premiere' space (car delivery area)
- 3 Bridge
- 4 Restaurant tower
- 5 Shop
- 6 Auditorium
- 7 Business centre
- 8 Hall with exhibition of cars (Level 0)
- 9 Bistro (Level 0)
- 10 Customer lounge (Levels 3 and 4)
- 11 Customers' exit ramp

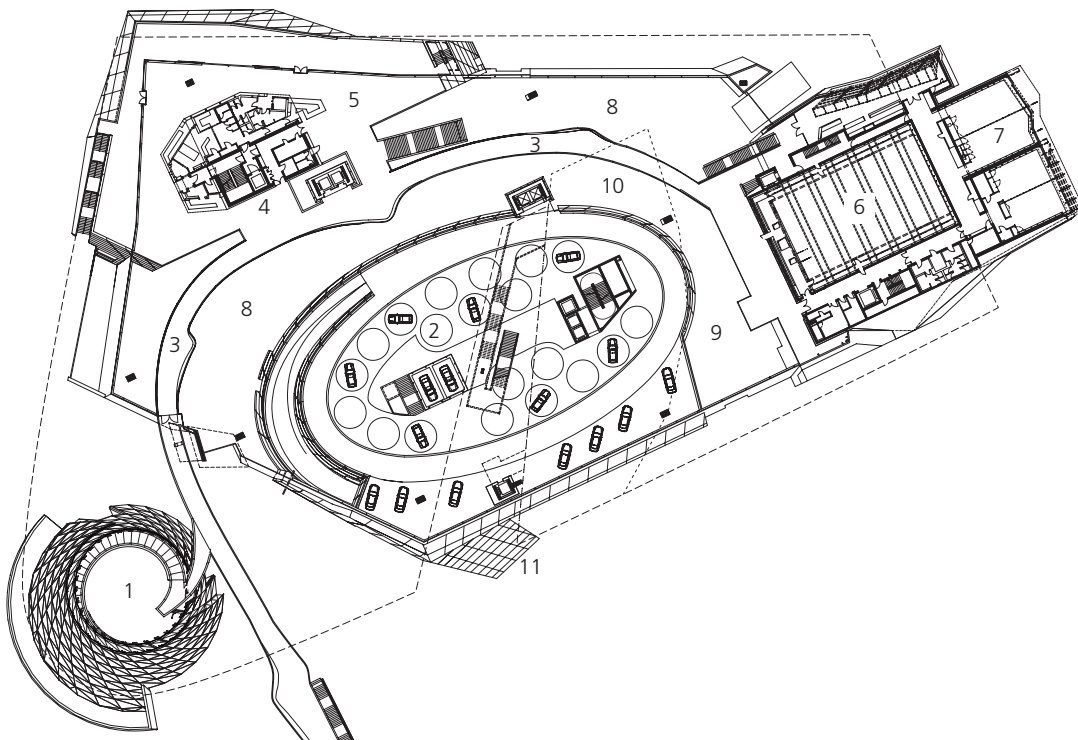



Its prominent position and unusual, curved shape make the 28-metre high double cone an ideal venue for temporary exhibitions and events. The cone's frame, its shape derived from a rotational hyperboloid figure, is a triangular lattice structure of hollow steel sections. Hot or cold water is pumped through these welded profiles in a closed loop, to heat the building in winter or cool it in summer. For the outer skin 900 different glass panels were used, each different in size, to fit the different dimensions of the triangular sections in the steel frame.

In front of this outer cladding, spaced 300 to 1200 mm from the glass, are perforated stainless steel sheets that provide solar shading. The lower part of this gap is accessible for maintenance work.

Located in a prominent position at a busy junction, the BMW Welt building culminates in an eye-catching double cone with dynamic, powerful lines.



A winding ramp fitted with 60 monitors turns the space into a media experience of sound and light; the ramp runs along inside the façade up to the narrowest point of the construction.

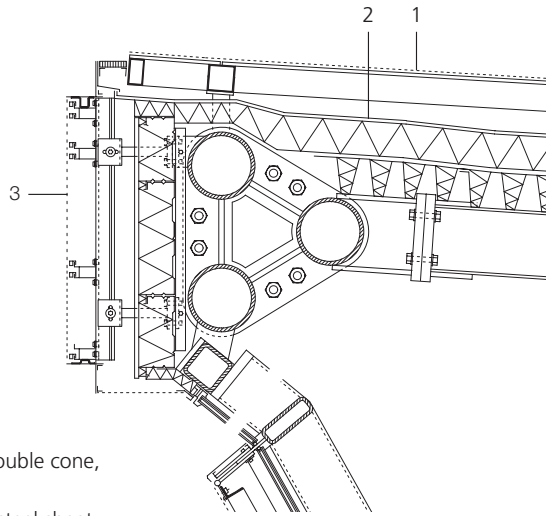

Section through double cone,
scale 1:40

- 1 3 mm stainless steel sheet,
fixed to a frame system of steel
sections
- 2 Water-circulating layer
- 3 3 mm stainless steel sheet
- 4 300/100 mm hollow-section steel
- 5 Glass:
2 x 6 heat-strengthened glass +
16 mm cavity +
8 mm toughened safety glass
- 6 Solar shading,
3 mm perforated stainless steel sheet,
partially openable for maintenance,
on 100/50 mm angle profiles

Stainless steel: grade EN 1.4401,
surface blasted with glass beads

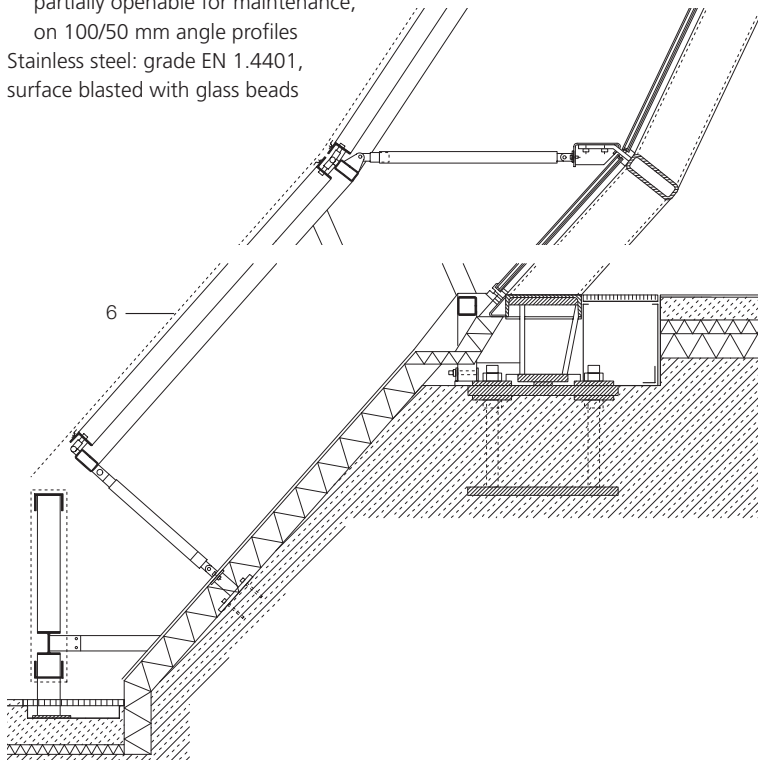
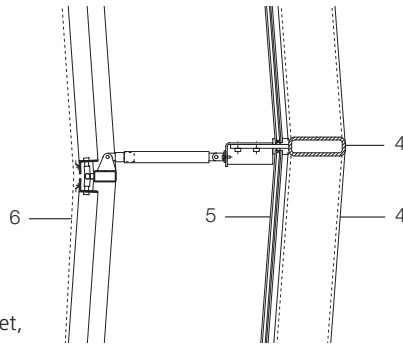

*Even the roof of the
double cone, curving in-
wards in the shape of a
tornado, is also covered
with stainless steel sheet.*

*Perforated, triangular
stainless steel sheet pro-
vides solar shading for
the glazed double cone.*

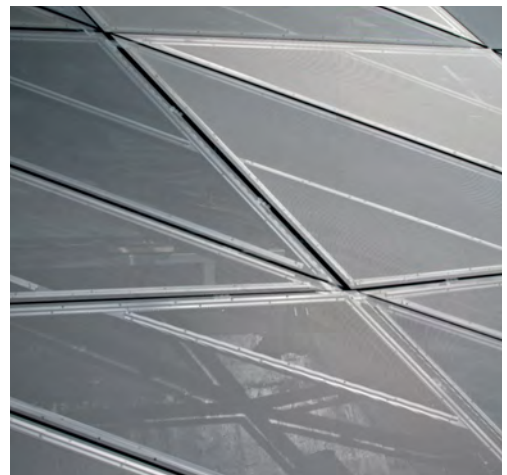

Inside BMW Welt all the public areas, such as the Forum, the restaurant tower and the double cone, are linked by a raised foot-bridge. At a height of 7.5 m above the hall floor, this bridge structure, clad with large-format panels of stainless steel, winds through the space like a corridor, forming a second level and articulating the vertical space.

The underside of the roof is also of stainless steel. The 5,000 panels, all of different dimensions, are perforated, which gives the roof a different appearance – ranging from corporeal to partially transparent – depending on the angle of incident light. Almost entirely encapsulated within the ‘cloud roof’ is the lounge where the customers gather for the hand-over event when they collect their new cars. Once the customer representative has gone over the last-minute details with them in the Product Info Center, the new owners then take delivery of their vehicles in

For reasons of visual continuity, no columns were used to support the foot-bridge – it rests instead on concrete supports cantilevered out from the restaurant tower and Forum and is suspended from the roof and lounge construction.



Along the raised foot-bridge, viewing bays tempt visitors to pause and survey the exhibition from above.

the ‘Premiere’ space, the centrepiece of the whole BMW Welt. Up to 170 cars can be handed over here each day, or around 45,000 each year. Before the hand-over they will have undergone final checks and been made ready in the workshops and workrooms in one of the four basement levels. From the ‘Premiere’ space customers then get behind the wheel of their car and drive down the curved ramp to the outside.

The full-height glazed façades allow inside and outside space to merge, while within the single-volume hall large-format stainless steel panels achieve visual continuity between the different functional zones. The matt gleam on the surface of the three-dimensionally curved 2 mm and 3 mm stainless steel sheets (grade: EN 1.4301) was achieved by blasting with glass beads.

Section through the 'Premiere' space
scale 1:40

- 1 Cladding, 3 mm stainless steel, grade: EN 1.4301, glass-bead blasted finish, 15 mm joint width
- 2 Supporting frame, lightweight metal, 3 mm sheet and profiles
- 3 Load-bearing frame of HEB 100 steel sections, U 80 and U 100 connector profiles
- 4 Ramp, reinforced concrete with special coating
- 5 Guardrail with integrated lighting

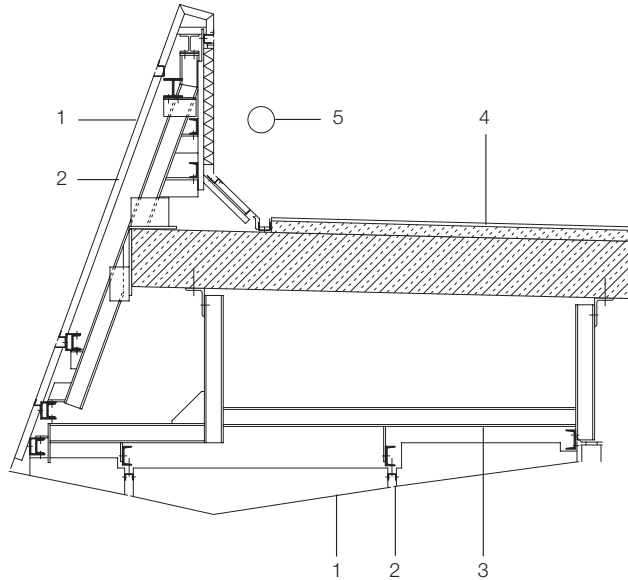

Awaiting collection: The new cars are displayed on 30 presentation platforms, some of them rotating.





The northern part of BMW Welt is dominated by the Event Forum, containing an auditorium and a conference area, the latter cantilevered out 20 m.

The high standards of design continue on the roof, or fifth façade, of BMW Welt. Integrated here in plane with the stainless steel roof covering are 3,600 glass-foil modules making up an 8,000 m² photovoltaic system. To avoid any visual interference from air vents and other necessary penetrations in the roof, the 3 mm stainless steel sheets are raised up on a frame system above the actual drainage layer. Grade EN 1.4401 stainless steel was chosen for these panels to cope with the higher levels of fine-particle emissions and abrasion dust from brake linings in the air around the busy traffic intersection. At the wish of the architects, the roof panels were also blasted with glass beads, creating a relatively rough surface which will need to be protected against a build-up of damaging deposits. Regular cleaning is carried out on the façade facing the ring road.

Euro Inox
 Diamant Building, Bd. A. Reyers 80,
 1030 Brussels, Belgium
 Tel. +32 2 706 82 67
 Fax +32 2 706 82 69
 E-mail info@euro-inox.org
 Internet www.euro-inox.org

Client: BMW AG, Munich
 Design and construction: COOP HIMMELB(L)AU
 Wolf D. Prix, Helmut Swiczinsky + Partner, Wien
 Project architect: Paul Kath
 Structural engineers:
 B+G Ingenieure, Bollinger und Grohmann GmbH,
 Frankfurt
 Schmitt, Stumpf, Frühauf + Partner, Munich
 Text and layout: Martina Helzel, circa drei, Munich
 Translation: Ingrid Taylor, Munich
 Photos: BMW AG, Munich